

STRAPPING

MOD.
06RP

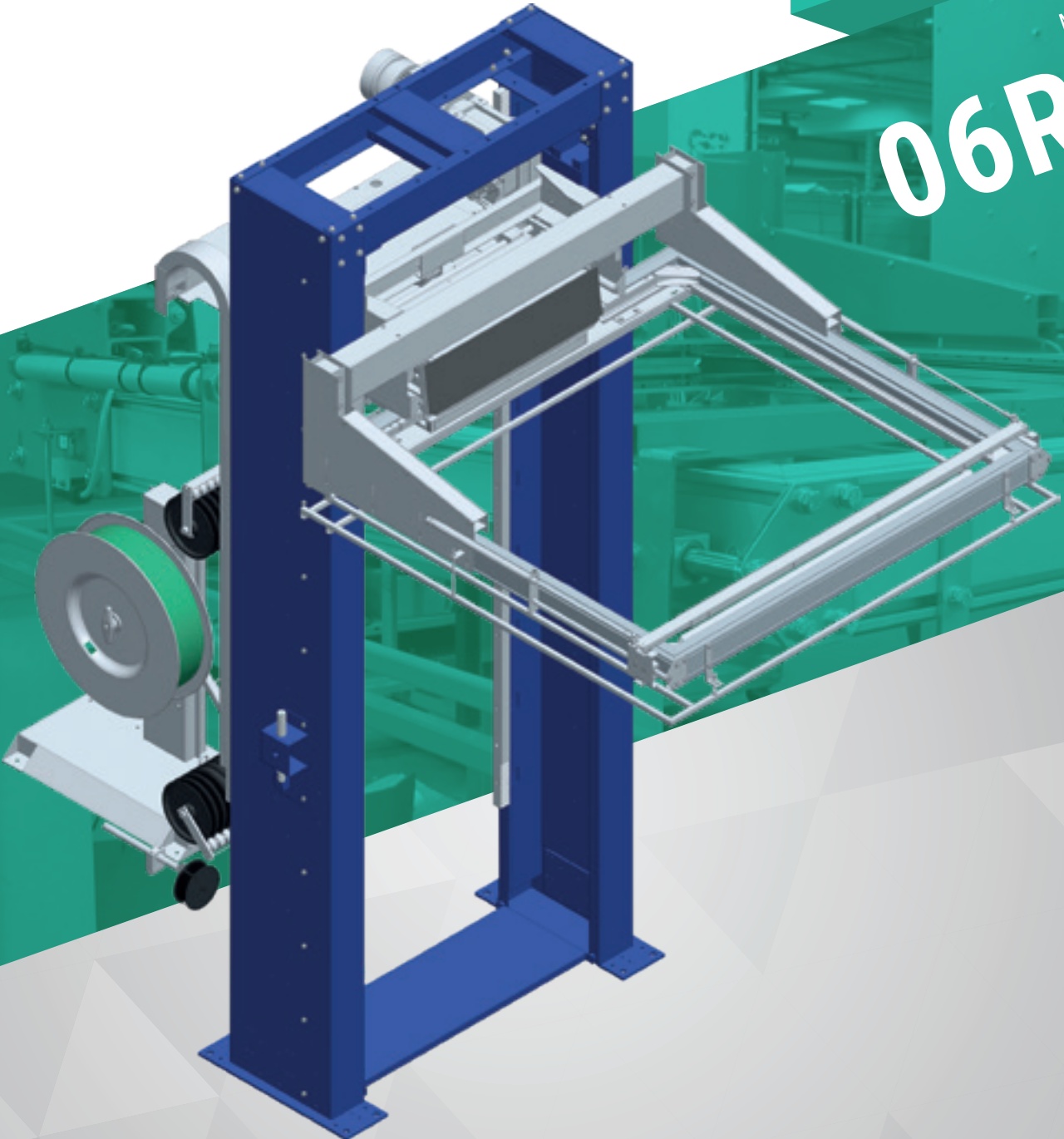

 **Applications**



Construction



Plastic/Cans



Glass

06RP Series

The 06RP automatic horizontal strapping machine was designed to apply horizontal straps to palletized products. It comes with a strapping head that works either with polypropylene or polyester straps. It can be placed in full automatic packaging lines,

where, by signals exchange can communicate with other machines. It can also operate in stand alone mode. It may also feature a touch-screen operator panel through which to manage all machine functions.

Technical data

Power supply

Voltage	400 V (50Hz)
Installed power	~ 2,0 kW

Air supply

Pressure	5,5 ÷ 6,5 bar
Consumption	~ 10 NL/cycle

Coil size

Max internal diameter	390 ÷ 405 mm
Max external diameter	600 mm

Pack size (standard machine)

Length	1200 mm
Width	800 / 1000 mm

Applicable strapping heads

TR1400 / TR1400HD / TR1800 / TR2000

Strap

Type of strap	Polyester (PET) Polypropylene (PP)
---------------	---------------------------------------

Standard machine dimensions

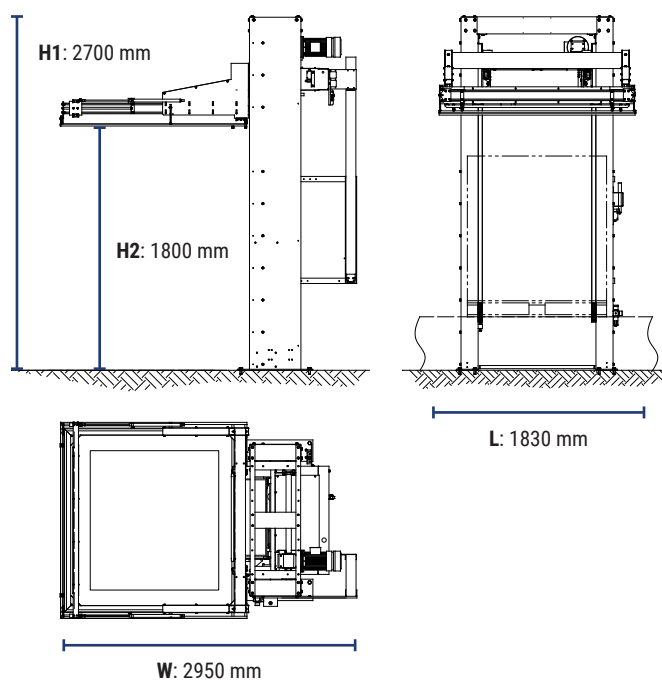

Strapping arch detail



Corners protection device



Officina Meccanica Sestese S.p.A.

Via Borgomanero, 44 - 28040 Paruzzaro (NO)

Tel. +39 0322 541411 Fax +39 0322 53157

www.omsspa.com

info@omsspa.com

As a part of our policy of continuous improvement, we reserve the right to alter design and specifications without prior notice. This brochure is for descriptive purpose only. Some of the items pictured in this brochure are optional and not standard equipment.