

 **Applications**



Logistic



Construction



Plastic



Ceramic



Glass

FT22

The new automatic FT22 thermoshrinking oven is a machine which uses a single workstation to package products through thermoshrinking. This new model shrinks the film, thanks to a new work cycle mode: each single side of the package is heat-shrunk in a single phase; up and down in alternate phases.

This guarantees a reduction of the total cycle time and the use of a smaller quantity of gas, thus preserving the burner lifetime. The pack must be positioned on the rotary platform with the use of appropriate means and it can be easily centered thanks to the guides thereon.

Technical Data

Power supply	
Voltage	400 V (50Hz)
Installed power	~ 2,0 kW

Gas supply	
Pressure	200 mbar +/- 20%
Consumption based on pack size, film thickness and burner size	

Pack size	
Length	1200 mm
Width	800 / 1000 mm
Height	Max. 2000 mm

Turntable dimensions	
Diameter	ø 1800 mm

Production	
Capacity	10/12 packs/hour

Options

- > Gas pressure reduction ramp
- > Pack loading ramp
- > Burial frame
- > Pallet support frame

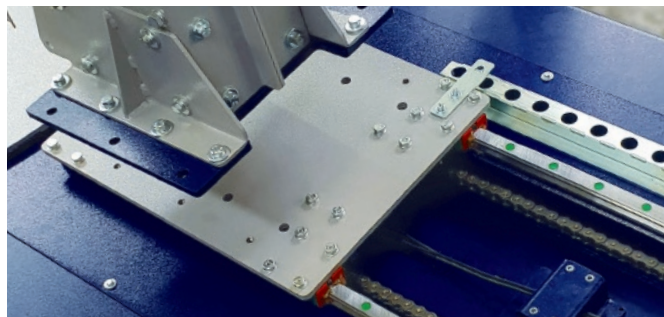

Movement guides detail

Standard machine dimensions

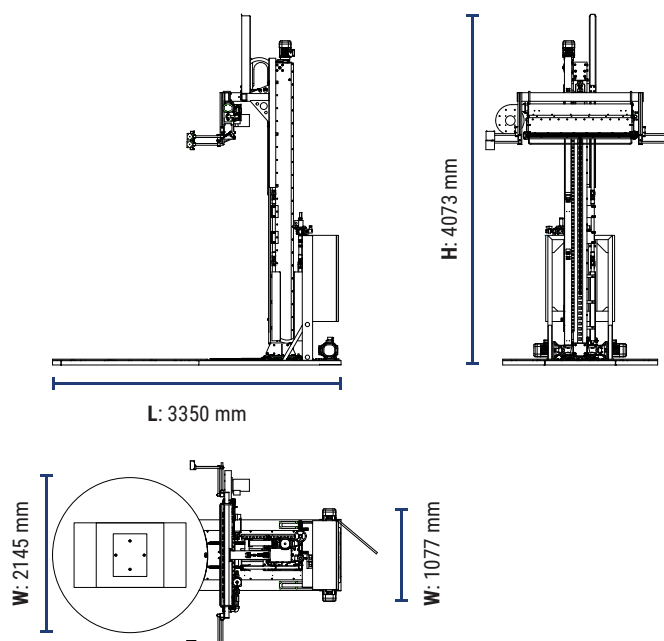

Burner detail



Officina Meccanica Sestese S.p.A.

Via Borgomanero, 44 - 28040 Paruzzaro (NO)

Tel. +39 0322 541411 Fax +39 0322 53157

www.omsspa.com

info@omsspa.com

Come parte della nostra politica di miglioramento continuo, ci riserviamo il diritto di modificare il design e le specifiche senza preavviso. Questo opuscolo è solo a scopo descrittivo. Alcuni degli articoli raffigurati in questa brochure sono opzionali e non di serie.