



PACKAGING TECHNOLOGIES

**SPINNY
S 500**



Automatic wrapping machine with 10 wrapping cycles >



Spinnny S 500 > Upgrade your wrapping saving cost and time!

EFFE 3 TI

ITALIAN



TECHNOLOGY



Are your pallet wrapping costs too high?

The Spinnny S 500 technology helps you to reduce costs and packing time!

SPINNY S 500 TOUCH SCREEN

Advantages > cost saving / easy to use / secure loads

- > **The power pre-stretch system** considerably reduces the stretch film consumption
- > Reduced stretch film consumption means **lower costs** and **environmentally friendly loads**
- > Device to reduce the film width into a band to increase the grip on the pallet **for more stability of the load**
- > Thanks to **ten programmable wrapping cycles**, the wrapping operation can be carried out very easily, within a shorter time and with less operator input
- > **Touch screen** allows fast programme settings and easy operation
- > Thanks to the average wrapping cycle time of **less than 80 sec.** high production rates are possible

Description > Automatic pallet wrapper with turntable and touch screen command panel

- > Device to reduce the film into a band at the end of the wrapping cycle
- > Automatic film clamp, welding and cutting device
- > Touch screen with 10 programmable and lockable wrapping cycles
- > Powered pre-stretch film carriage for up to 300% pre-stretch ratio
- > Photocell for automatic height detection of loads suitable also for black products
- > Inverter for soft start and stop of the turntable with rotation speed adjustable from 5 to 15 RPM
- > Speed of film carriage adjustable by inverter – separate setting of ascent and descent speed



SPINNY S 500 EASY TOUCH

Technical Data >

- > Max. height of wrapping mm. 2600
- > Turntable diameter mm. 1650
- > Max. load capacity Kg. 2000
- > Electric supply single phase 230 V - 240 V 50 Hz.
- > Max. pallet size mm. 1200x1000
- > Average wrapping cycle less than 80 sec.

Options >

- > Electro-Mechanical top plate powered by a gear-box motor
- > Remote control unit

Customized machines on request.

Overall dimensions >

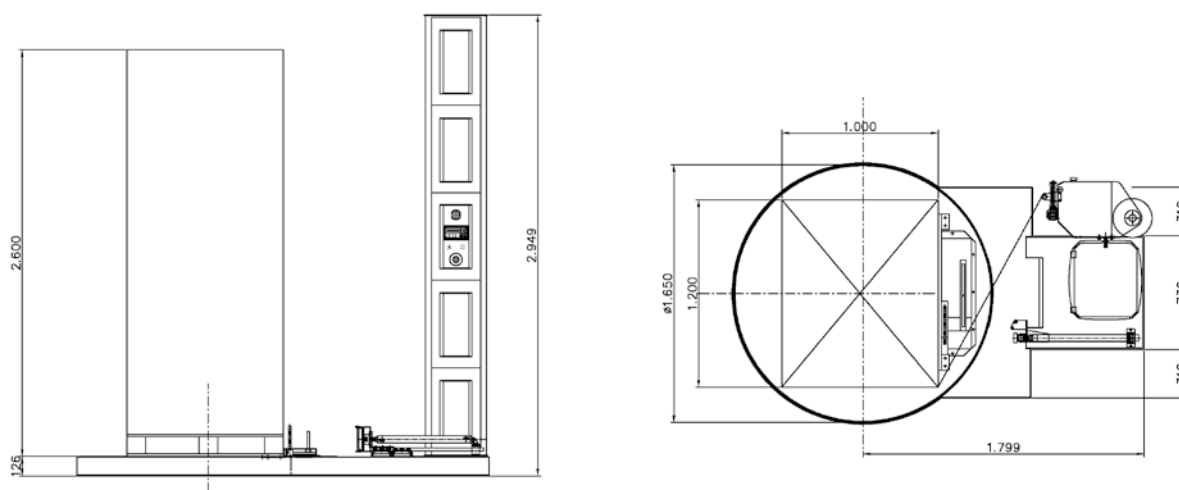

EFFE3TI srl
C.so Garibaldi, 298
Gattinara 13045 (VC) ITALY

Tel. 0039 0163 828911
Fax 0039 0163 828990

info@effe3ti.com
www.effe3ti.com